



***REVOLUTION D.F.2***  
***850W / 1050W / 1200W***



## ***REVOLUTION D.F. 2***

- **80 PLUS® GOLD Certified Power Supply**
- **Dust-free Rotation (DFR) Function**
- **100% Japanese Electrolytic Capacitors**
- **Half Bridge LLC Resonant Converter & DC to DC Circuit Design**
- **14cm High-compatibility Chassis**
- **Smart Semi-fanless & Silent 12 cm FDB Fan**
- **2X Peak Power Output**



## Features

- **Longer Lifespan**
  - Dust-free Rotation function enable fan to activate self-cleaning when powering up
- **Efficiency & Security**
  - 80 PLUS® GOLD certification delivers up to 90% efficiency at 50% power load
  - 100% Japanese electrolytic capacitors, which offer stability and reliability to prolong lifespan
  - Multiple protection circuitries of OCP, OVP, UVP, OPP, SCP and OTP that provide secure experience
  - 2 times peak power output provides more safety during heavy usage
- **Awesome Compatibility**
  - Half bridge LLC resonant converter & DC to DC circuit design offers higher output efficiency and voltage stability
  - Single rail +12V design, which bears higher electric current avoids PSU shutting down from heavy usage
- **Silent Operation**
  - Semi-fanless function for absolute silence under 20% load
  - 12cm FDB fan provides a silent environment
- **User Friendly**
  - 14cm high-compatibility chassis provides more options for friendly installation in most of mainstream cases

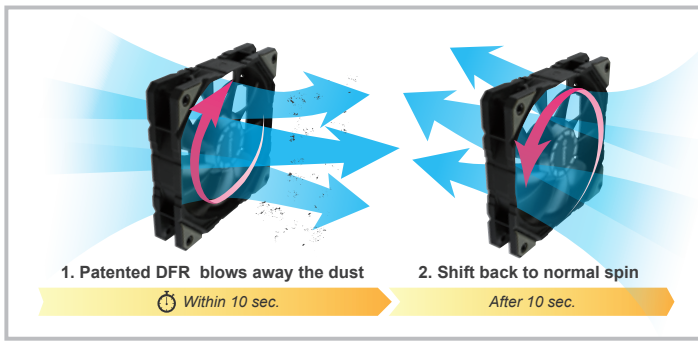

Dust-free Rotation (DFR) Function

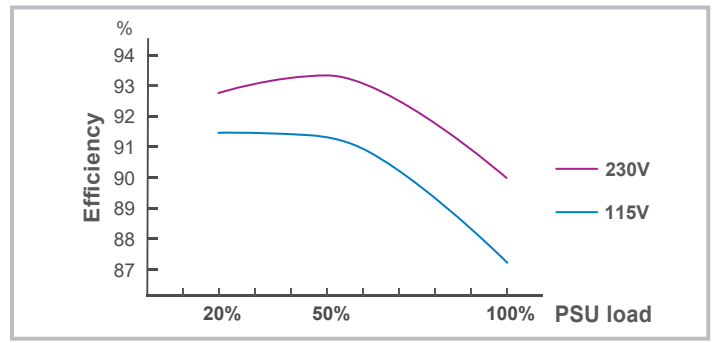

80 PLUS® GOLD Certified

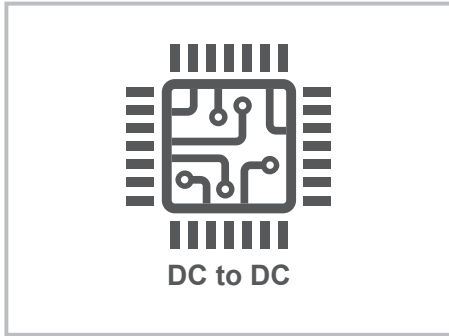

Half Bridge LLC Resonant Converter & DC to DC Circuit Design

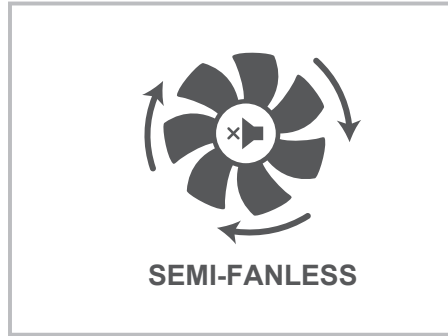

Smart Semi-fanless

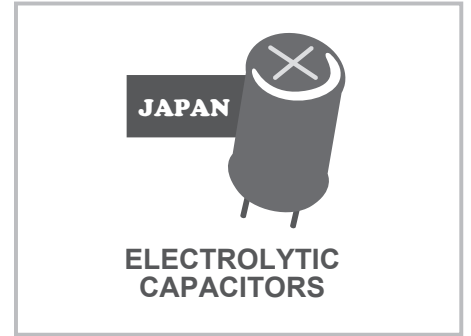

100% Japanese Electrolytic Capacitors

## Dimension

Unit : mm

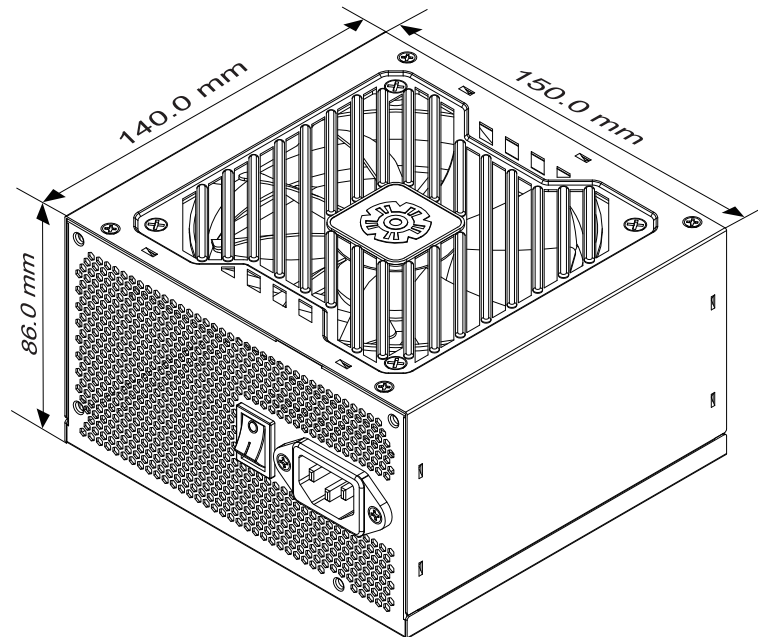

## Cables & Connectors

Product	Modular Cables					
	Mainboard 24P	CPU 4+4P (8P)	PCI-E 6+2P (8P)	SATA	4P Molex	FDD (adapter)
850W	1	2	6	8	4	1
1050W	1	2	6	8	4	1
1200W	1	2	8	8	4	1

# Specifications

Model Number	ERS850EWT		ERS1050EWT		ERS1200EWT	
AC Input Voltage	100-240VAC, 47-63Hz		100-240VAC, 47-63Hz		100-240VAC, 47-63Hz	
AC Input Current	11-5.5A		13-6.5A		15-7A	
DC Output						
	Rated	Combined	Rated	Combined	Rated	Combined
+3.3V	20A	130W	20A	130W	20A	130W
+5V	20A		20A		20A	
+12V	70.5A	846W	87.5A	1050W	100A	1200W
-12V	0.3A	3.6W	0.3A	3.6W	0.3A	3.6W
+5Vsb	2.5A	12.5W	2.5A	12.5W	2.5A	12.5W
Total Power	850W		1050W		1200W	
Dimensions	150(W) x 86(H) x 140(D)mm					



## Logistic Information

Model		ERS850EWT	ERS1050EWT	ERS1200EWT
Bar code	EAN	4713157727305	4713157727312	4713157727329
	UPC	819315027301	819315027318	819315027325
Box Dimension		305 x 200 x 95 mm		
Gross Weight / Unit		2.39KG	2.51KG	2.60KG
Carton Dimension		495 x 325 x 225 mm		
Q'ty / Carton		5pcs		
Gross Weight / Carton		12.55KG	13.15KG	13.89KG